

Step it up a notch with the P5-RM from Point Five Packaging. This semi-automatic tray seal system is capable of producing vacuum, MAP (vacuum gas), vacuum skin packing (VSP) and sealing of pre-formed trays and cups. The manual turntable operation considerably cuts cycle times and optimizes output. It allows the operator to load and unload trays at one station while the machine is performing a seal operation at the other. When ready, the operator will rotate the table and the cycle begins again.

The P5-RM is fitted with easy to load film rack and automatic film advance. An optional print registered film operation and an automatic tray lifter for easier loading/unloading. The P5-RM can run up to 16 MAP trays, 28 sealed trays and 12 vacuum skin pack trays per minute. Quick change seal heads can be changed out in less than 2 minutes. A user-friendly touch screen display allows easy product set-up, storage of up to 99 product recipes and multiple language selection including English, Spanish and French.

INCREASED PERFORMANCE

System Advantages

- Stand alone, self-contained and portable with an easy to operate manual turntable
- Dual vacuum chamber turntable considerably cuts cycle times and maximizes output
- Heavy duty 304 stainless steel construction ideal for food packing environments
- User friendly, 7.2" PLC color touch screen, operator interface
 - Up to 99 stored product recipes
 - Language selection (English, Spanish or French)
 - Integrated temperature control
 - Menu-driven MAP parameters including gradual vacuum and sealing only
 - USB/Ethernet port
- NEMA 4X electrical enclosure
- All electrical components are UL rated
- Interlocked safety guarding
- Easy to load film rack with automatic scrap take up
- Tool-less vacuum chamber removal ensures high standards of hygiene and cleanliness
- Affordable, easy seal head change in less than 2 minutes - optional seal head storage cart with pre-heating feature
- Produce MAP, non-MAP, and VSP packs on the same seal head
- Various vacuum pump sizes optional



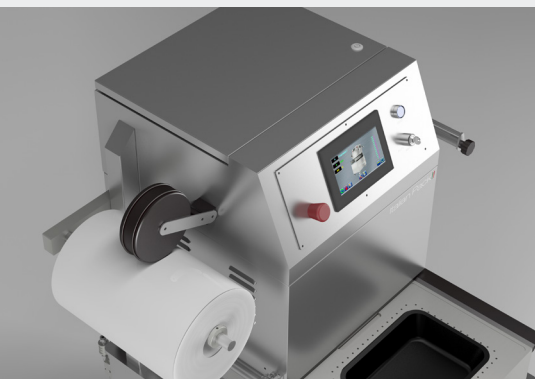

Operator friendly color touch screen

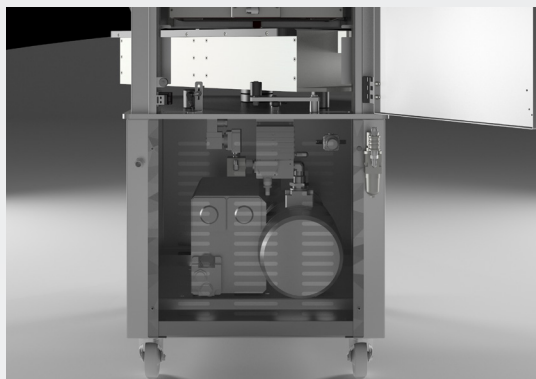

Various vacuum pump options



Simple manual turntable operation

Technical Specifications

Machine Sizes (inches)

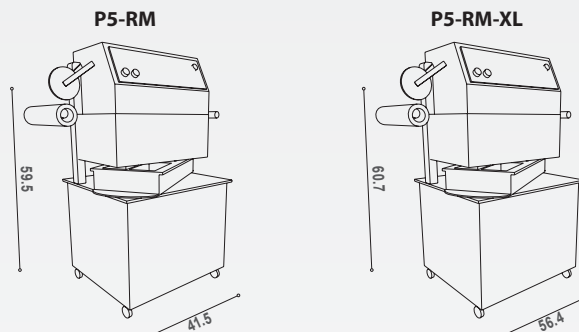

	P5-RM	P5-RM-XL
Weight lbs (kg)	660 (300)	770 (350)
Frame Construction	304 Stainless Steel	304 Stainless Steel
Electrical Supply (standard)	220V 3Ph 60HZ	220V 3Ph 60HZ
Power Supplied (amp)	4 - 13.5	4 - 13.5
Standard Vacuum Pump Size (m ³ /h)	43	43
Optional High Vacuum Pump Sizes (m ³ /h)	63 / 100	63 / 100
Max Reel Film Width Inches (mm)	14.5 (370)	14.5 (370)
Max Reel Film Diameter Inches (mm)	9.75 (250)	9.75 (250)

Maximum Trays Dimensions	P5-RM	P5-RM-XL
1 up	15.7x12.2" 400x310mm	22.2x13.4" 565x340mm
2 up	7.5x12.2" 190x310mm	11x13.4" 269x340mm
3 up	4.7x12.2" 120x310mm	6.7x13.4" 170x340mm
4 up	7.5x5.7" 190x145mm	10.6x6.1" 269x156mm
Max Depth	5.5" (140mm)	
6 up	6.7x6.1" 170x156mm	
Max Depth	5.5" (140mm)	

Operation	2 station manual rotary	2 station manual rotary
Operating System	7.2" color touch screen with built in PLC	7.2" color touch screen with built in PLC
Cycle/min	3/8	3/8
Packaging Options	No MAP Sealing Gas Flush Vacuum-Gas Vacuum Only Vacuum Skin Pack	No MAP Sealing Gas Flush Vacuum-Gas Vacuum Only Vacuum Skin Pack